



Logalkor Solutions

www.logalkor.com

LGZ Small Universal Tensile Testers



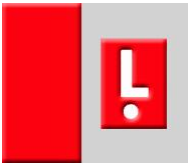

LGZ- series Standard Machines

For tension and compression

made of massive Aluminum and stainless steel ball bearings and ball screws

Z3-X500 3 kN small tensile tester movement 500mm distance 66mm

Z5-X500 5kN dto but 5kN

Z3-X1200 longer version with movement 1200 mm

Z5-X1200 5kN dto but 5kN

Z10-X700 10 kN version 700 mm movement with two guides width 400mm

Z10-X1200mm 10 kN version 700 mm movement with two guides width 600mm

Z10-X1200mm 10 kN version 1200 mm movement with two guides

Heavy machine, two guides width 428 movement 700mm or 1200mm

Z20-X700, Z20-X1200 20kN

Z30-X700, Z30-X1200 30kN

Z50- X700, Z50 -X1200 50 kN

AC-Servo System Stöber

Microprocessor controlled standalone (working without external computer)

Interface USB

2 line LCD shows force and distance for Standalone Modus

Measuring length with HP-Encoder

accuracy to be seen on LCD 0.01 mm (internal 0.0001 mm)

Standard load cell: 0.03% linearity with calibration certification

AD counter makes 24 Bit with 6.35 /sec With 50 Measurements per sec 21 Bit

Guaranteed Resolution with a standard load cell to be seen is $\pm 100\ 000$ parts with a rate of 50 Hz per second in standard delivery

resolution with 50 measures per second is $10\text{kN}/100000 = 0.1\text{N}$ or 0.022lbf pound

if it is necessary resolution can be switched up to 2 000 000 with less speed 6.25 values per second

– useful only with special high precision load cell

Optional we can add a second channel for a second load cell or an extensiometer

(10kN = 2248 pound)

Load Cell Data

| | | | |
|-----------------------------|----------------|-------------------------------|----------------|
| MINIMUM RANGE | 25% | b) service load | 100% |
| COMBINED ERROR | < +/- 0.04% | c) max. permissible load | 120% |
| NON REPEATABILITY FS | < +/- 0.01% | d) breaking load | >300% |
| Creep % FS 30 min. 20 MIN | < +/- 0.03 | e) max. side load | 100% |
| TEMPERATUR EFFECT 10°C | | PROTECTION CLASS 50..1kN | IP64 |
| on zero | < +/- 0.05 % | 2kN ... 100kN | IP65 |
| on span | < +/- 0.1 % | Potted and seal | 50N ... 5000N |
| NOMINAL SENSITIVITY +/-0.01 | 3mV/Volt | Potted and metal seal | 10kN ... 200kN |
| INPUT RESISTANCE | 385 +/- 10 Ohm | NOMINAL TEMP. RANGE | - 10/+40 °C |
| OUTPUT RESISTANCE | 350 +/- 3Ohm | SERVICE TEMP. RANGE | -20/+70 °C |
| ZERO BALANCE FS | +/-1.0% | CELL MATERIAL (Nickel Plated) | Tool Steel |
| SUPPLY VOLTAGE | 5V - 15 Volt | CABLE | Ø5 x 5 meter |



Logalkor Solutions

www.logalkor.com

Software for Stand Alone Usage

Machine is able to work without PC two Modes:

1) Constant speed regulation

During test machine shows actual values of force and load. After the test it shows the maximum value of the force and the max. extension.

Break force and Break Position is also visible

2) Constant force regulation

Machine tries to keep force constant during an adjustable time.



Program in machine can be changed via PC and USB (via Downloader)

Languages switchable on LCD: German, English, Spanish, French Danish, Italian

Windows Programm

Program for Microsoft Windows XP, Windows 7, 8 to move machine, collect and save data is included in basis delivery

It also contains a printout and statistic

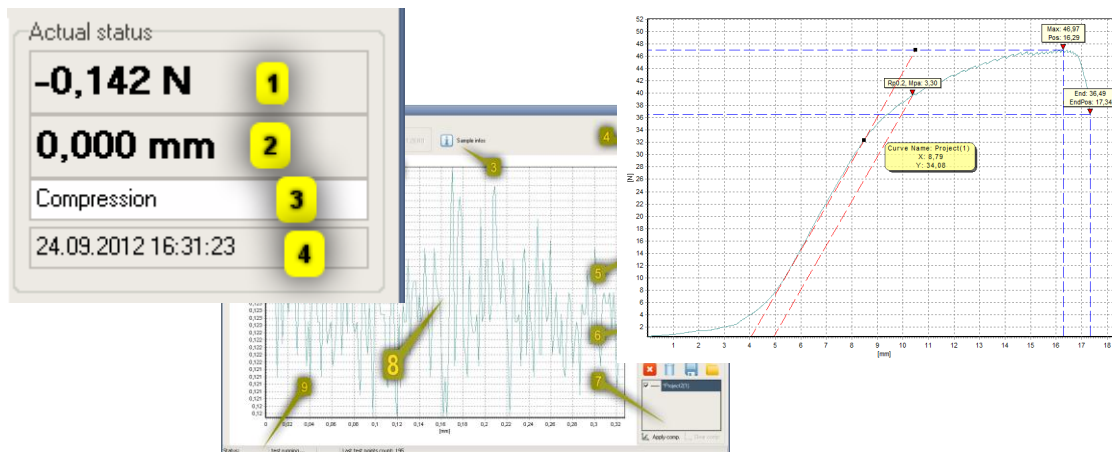

Sound

28 dBA without load

41 dBA with a speed of 100mm/min

56 dBA with a speed of 500mm/min

Scope of delivery

Machine, Loadcell, 220 Volt cabel, USB cabel, Software on CD, Description ,CE conformity declaration, Package

All machine from family LGZ3-LGZ10 have a Trafo for 110/220V

We deliver a Voltage selector. For Z3 and Z10 to work on 110-115V and 220-240V with 50-60Hz net.

Standard machines are configured to work in 220V mode

Warranty 1 year without travel cost



Logalkor Solutions

www.logalkor.com

| | LGZ3 | | LGZ5 | | LGZ10 | | LGZ20 | | LGZ50 | | LGZ100 | |
|------------------------------------|----------------------|----------------------|----------------------|----------------------|----------------------|--------------------|---------------------|---------------------|---------------------|---------------------|---------------------|---------------------|
| Max speed [mm/Min] | 700 | | 700 | | 600 | | 1600 | | 1600 | | 1000 | |
| min speed [mm/Min] | 1 | | 1 | | 1 | | 0.03 | | 0.03 | | 0.02 | |
| Smallest free distance [mm] | 66 | | 66 | | 200 | | 209 | | 209 | | 228 | |
| Adapter Size [mm] | 15.9 | | 15.9 | | 15.9 | | 31.8 | | 31.8 | | 40/12 | |
| Motor [Watt] | 50 | | 90 | | 170 | | 800 | | 1600 | | 2400 | |
| Voltage [-V] | 220/110 | | 220/110 | | 220/110 | | 380 | | 380 | | 380 | |
| Motor type | DC | | DC | | DC | | AC-Servo | | AC-Servo | | AC-Servo | |
| Producer | Maxon | | Maxon | | Maxon | | Stöber | | Stöber | | Stöber | |
| Movement [mm] | 500 | 1200 | 500 | 1200 | 700 | 1200 | 700 | 1200 | 700 | 1200 | 700 | 1200 |
| Weight [kg] | 36 | 37 | 55 | 56 | 80 | 105 | 235 | 260 | 245 | 270 | 380 | 420 |
| Dimensions [mm] | 1036 390 300 | 1677 390 300 | 1036 390 300 | 1677 390 300 | 1226 *640 *240 | 1726 640 240 | 1317 1071 433 | 1837 1071 433 | 1317 1071 433 | 1837 1071 433 | 1450 1090 590 | 2050 1090 590 |
| Packing Dimensions [mm] | 1150 *500 *400 | 1800 *500 *400 | 1150 *500 *400 | 1800 *500 *400 | 1315 *740 *400 | 1916 740 400 | 1900 1200 800 | 1900 1200 800 | 1900 1200 800 | 1900 1200 800 | 1600 1200 800 | 2100 1200 800 |



LGZ3- LG Z5-X500 3kN, 5 kN version 500mm movement small universal tensile tester



Logalkor Solutions

www.logalkor.com

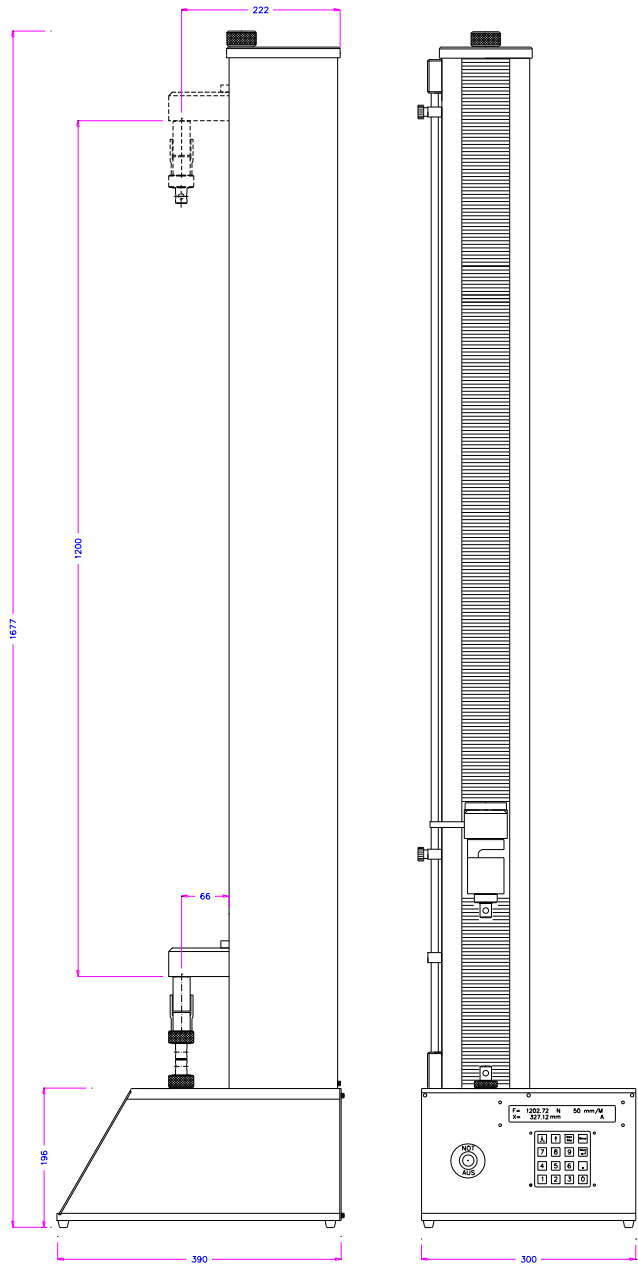

Z3-X1200

Z5-X1200

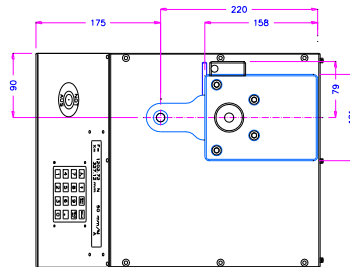

LGZ3- LGZ5-X1200 1200mm



Logalkor Solutions

www.logalkor.com

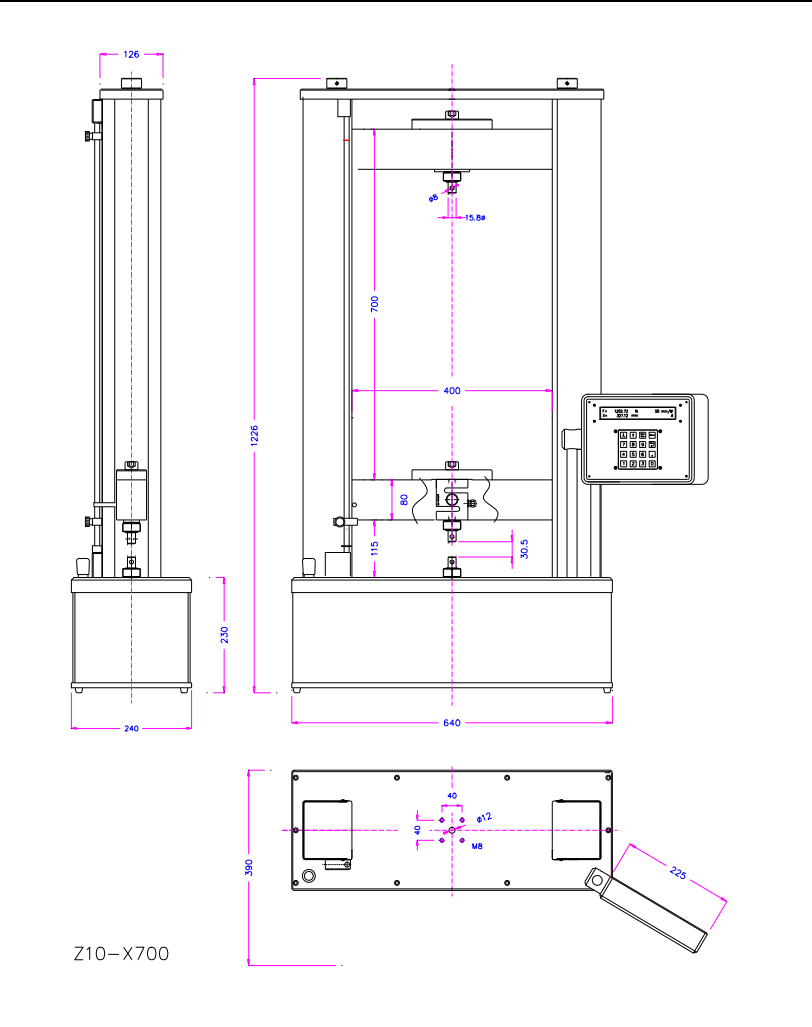

Z10-X700 10kN 700mm 400mm width



LGZ10-X700-W600 600mm width

LGZ10-X1200 + TH126+BW

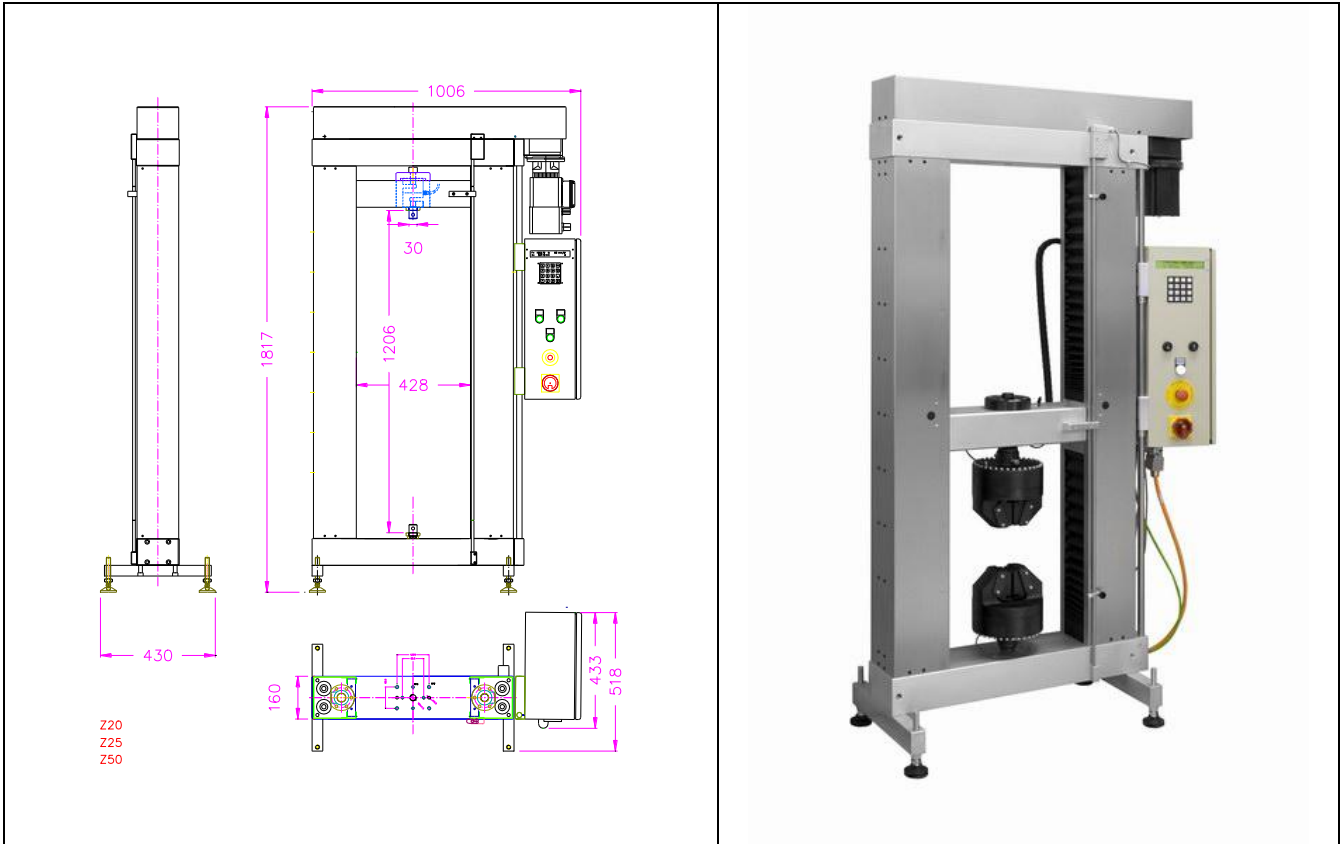

Z20
Z25
Z50

**Strong Universal Tensile Tester LGZ20 and LGZ50
(TH175-50 pneumatic wedge grip 50kN)**



Logalkor Solutions

www.logalkor.com

LGZ20- LGZ25- LGZ30- LGZ50-X700
700mm movement



LGZ100-X700

